

PIC Wire & Cable <i>A Division of the Angelus Corporation</i> Ph 262-246-0500 Fax 262-246-0450 PO Box 330 Sussex, WI 53089	Connector Specification	120609
	Approved <i>MCT</i>	Date 11/17/10
	Distribution : USER	Rev. 2 (06/11/13) Uncontrolled Document

TNCA 90° Straight Plug
for S28110 & HH85295F Cables

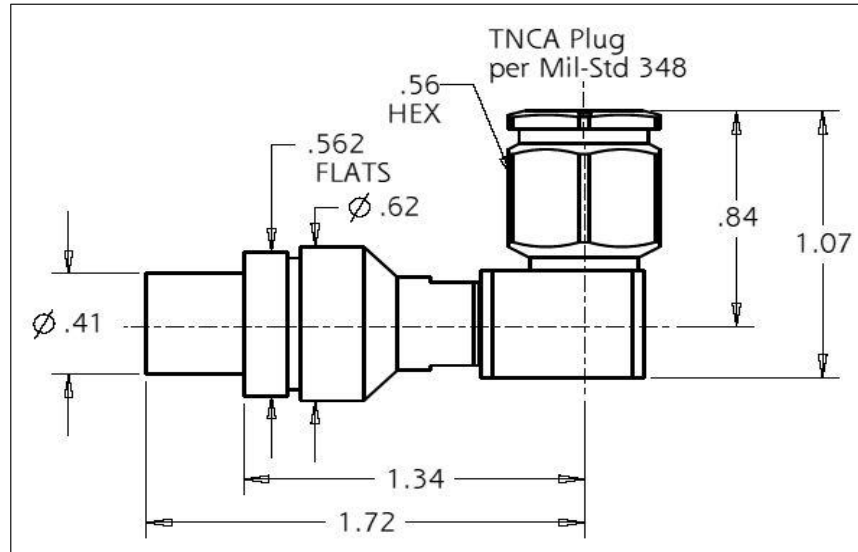

Features Not Shown : Gasket, Safety Wire Holes

PERFORMANCE

Nominal Impedance	50 Ohms
Frequency Range	DC - 18 GHz
Temperature Rating	- 65° to + 200° C
Voltage Rating	500 VRMS

CONNECTOR WEIGHT (Each)

2.02 ounces (57.38 grams)

RoHS COMPLIANT

Complies to RoHS Standards

INSTALLATION

Solder-on Termination

CONSTRUCTION

Materials:

Body	Stainless Steel
Coupling Nut	Stainless Steel
Solder Ferrule	Brass
Center Contacts	Beryllium Copper
Dielectric	PTFE
Gasket	Silicon Rubber

Finish :

Body, Coupling Nut	Passivated
Solder Bushing	Gold
Center Contact	Gold

<i>Applicable Standards</i>	MIL-STD 348B MIL-C-39012
-----------------------------	-----------------------------

Notes :

- 1) A 2.5" piece of Raychem ATUM heat shrink P/N ATUM-16/4-0 provided with connector for purpose of strain relief & moisture protection.
- 2) Please refer to T-120609 Termination Instruction sheet for strip dimensions & instructions.