

A Division of the Angelus Corporation  
 Ph (262) 246-0500 Fax (262) 246-0450 www.picwire.com  
 N220 W1051 Springdale Road, Waukesha, WI 53186

Approved: 

Date : 07/06/16

Rev. 4 (07/21/23)

Distribution : USER

Uncontrolled if Printed

**SMA (50 Ohm) 90° Plug**  
 for UH67163

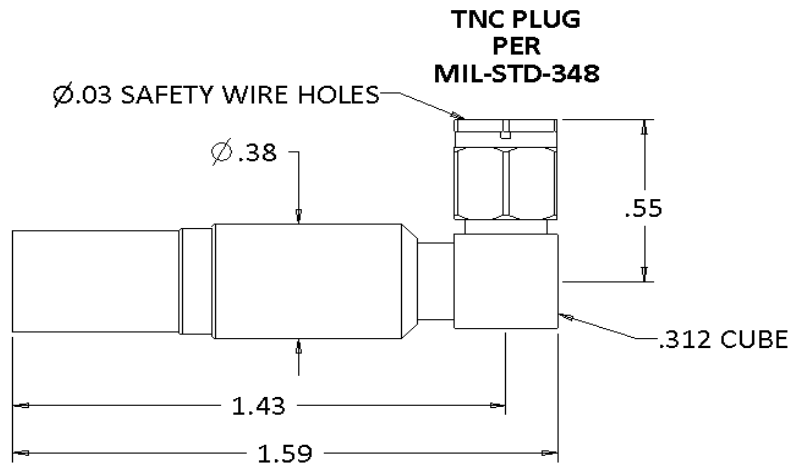

Features Not Shown : Safety Wire Holes, Gasket in Front

**PERFORMANCE**

Nominal Impedance :	50 Ohms
Frequency Range :	0 - 12 GHz
Voltage Rating :	335 V (rms)
Insulation Resistance :	5000 Megohms
DW Voltage :	750 V (rms)
Insertion Loss (max) :	0.52 dB max @ 12 GHz
Insertion Loss :	0.15 $\sqrt{f(\text{GHz})}$
Temperature Rating :	-65° to +165° C

**CONNECTOR WEIGHT (Each)**

0.65 ounces (18.48 grams)

**RoHS COMPLIANT**

Complies to RoHS Standards

**INSTALLATION****Center Contact**

Solder Only

**Crimp Ferrule**

M22520 / 5-01 Tool  
 M22520 / 5-41 Die Set  
 (.290" A hex)

**CONSTRUCTION****Materials:**

Body	Stainless Steel, ASTM-A582, Alloy UNS S30300
Connector Contact	Beryllium Copper, ASTM-B196, Alloy UNS C17300
Cable Contact	Brass, ASTM-B16, Alloy UNS 36000, Dead Soft,
Ferrule	Brass, ASTM-B16, Alloy UNS 36000, Dead Soft, Or Tellurium Copper, ASTM-B301, C14500, H02
Dielectric	TFE Fluorocarbon, ASTM-D1710, Type 1, Grade 1
Gasket	Silicone Rubber per A-A-59588

**Finish :**

Body	Passivated
Ferrule	Nickel
Center Contact	Gold

**APPLICABLE STANDARDS**

MIL-STD 348, MIL-PRF-39012

**Notes :**

1) A 1.5" piece of Raychem ATUM heat shrink  
 P/N ATUM-12/3-0 provided with connector for  
 purpose of strain relief & moisture protection.

2) Please refer to T-1505XX Termination Instruction  
 sheet for strip dimensions & instructions.