

PIC Wire & Cable <i>A Division of the Angelus Corporation</i> 262-246-0500 Fax 262-246-0450 PO Box 330 Sussex, WI 53089	Connector Specification	P/N 190008
	Approved <i>MCT</i>	Date 01/15/03
	Distribution : USER	Rev. 3 (06/11/13) Uncontrolled Document

ARINC 600 Modified Size 1 Socket to TNC Jack Adapter

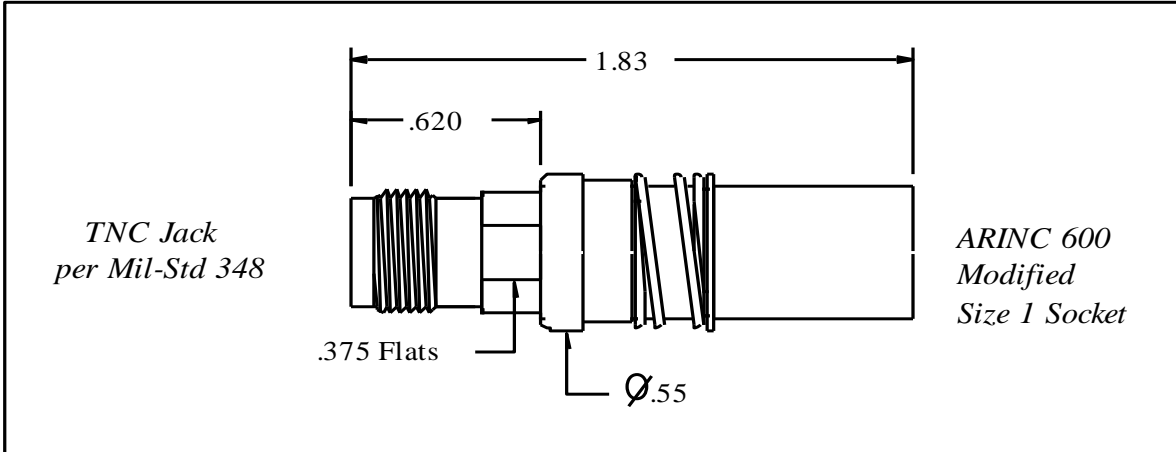

PERFORMANCE

Impedance	50 Ohms
Frequency Range	0 - 5 GHz
Voltage Rating	500 VRMS
Insulation Resistance	5000 Megohms

CONNECTOR WEIGHT (Each)

.85 ounces (24.26 grams)

RoHS COMPLIANT

Complies to RoHS Standards

CONSTRUCTION

Materials:

Connector Body	Brass, ASTM-B16, Alloy UNS 36000, H02
Center Contact	Beryllium Copper, ASTM-B196, Alloy UNS C17300
Dielectric	TFE Fluorocarbon, ASTM-D1710, Type 1, Grade 1
Mounting Spring	Stainless Steel, ASTM 313
Retaining Ring	Stainless Steel, PH 15-7

Finish :

- Body	Gold
- Center Contact	Gold
- Spring, Ring	Passivated

Applicable Standards

ARINC 600
 Mil-Std 348
 MIL-PRF-39012