

A Division of the Angelus Corporation
 Ph (262) 246-0500 Fax (262) 246-0450 www.picwire.com
 PO Box 330 Sussex, WI 53089

Approved : *MCS*
 Distribution : USER

Date : 03/05/02
 Rev. 2 (06/16/14)
 Uncontrolled if Printed

TNC 75° Coaxial Plug Connector

for S44191, S44193, S46191
 or RG400, RG142

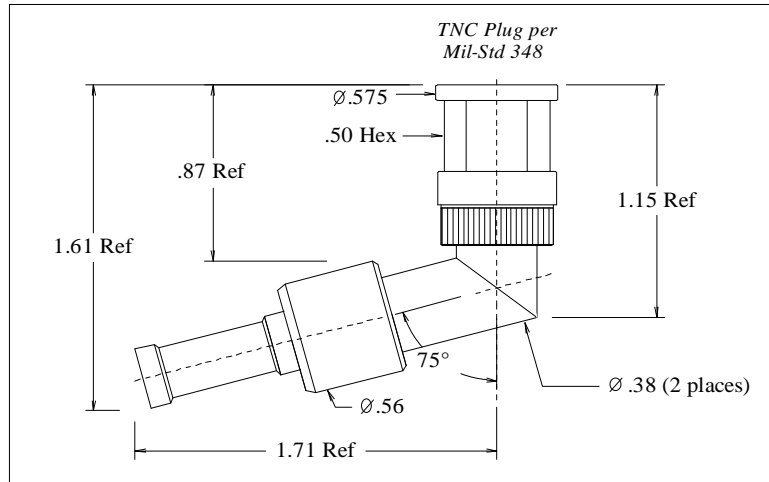

Features Not Shown: Safety Wire Holes, Seal in front

PERFORMANCE

| | |
|-----------------------|--------------|
| Nominal Impedance | 50 Ohms |
| Frequency Range | 0 - 12 GHz |
| Voltage Rating | 500 VRMS |
| Insulation Resistance | 5000 Megohms |

CONNECTOR WEIGHT (Each)

1.31 ounces (38.78 grams)

RoHS COMPLIANT

Complies to RoHS Standards

INSTALLATION

| | |
|--------------------------|-------------------------|
| Pic Die Set | MIL Spec Die Set |
| Center Contact | Center Contact |
| M22520 / 5 - 01 Tool, | M22520 / 5-01 Tool, |
| PIC 190118 Hex Crimp Die | MIL Spec *M22520 / 5-57 |
| (.098 hex) | (.100 B hex) |
| Crimp Ferrule | Crimp Ferrule |
| M22520 / 5 - 01 Tool, | M22520 / 5-01 Tool, |
| PIC 190118 Hex Crimp Die | MIL Spec *M22520 / 5-57 |
| (.213/.261 hex) | (.213 A hex) |

CONSTRUCTION

Materials:

| | |
|----------------|--|
| Body | Brass, ASTM-B16, Alloy UNS 36000, H02 |
| Center Contact | Beryllium Copper, ASTM-B196, Alloy UNS C17300 |
| Ferrule | Brass, ASTM-B16, Alloy UNS 36000, Dead Soft, Weatherseals included |
| Dielectric | TFE Fluorocarbon, ASTM-D1710, Type 1, Grade 1 |

Finish :

| | |
|----------------|--------|
| Body, Ferrule | Nickel |
| Center Contact | Gold |

Applicable Standards MIL-STD 348
 MIL-PRF-39012

Notes :

- 1) A 2.5" piece of Raychem ATUM heat shrink P/N ATUM-16/4-0 provided with connector for purpose of strain relief & moisture protection.
- 2) Please refer to T-190XXX Termination Instruction sheet for strip dimensions & instructions.

* Note - MIL Spec die to be used on the smaller diameter area of ferrule only. Not the larger "Bell" areas on each end.