

PIC Wire & Cable <i>A Division of the Angelus Corporation</i> Ph 262-246-0500 Fax 262-246-0450 PO Box 330 Sussex, WI 53089	Connector Specification	110466 User Spec
	Approved <i>M.E.J.</i>	Date 11/28/07
	Distribution : USER	Rev. 3 (06/25/13) Uncontrolled Document

TRB 90° Triax Plug
for L8620TX Cable

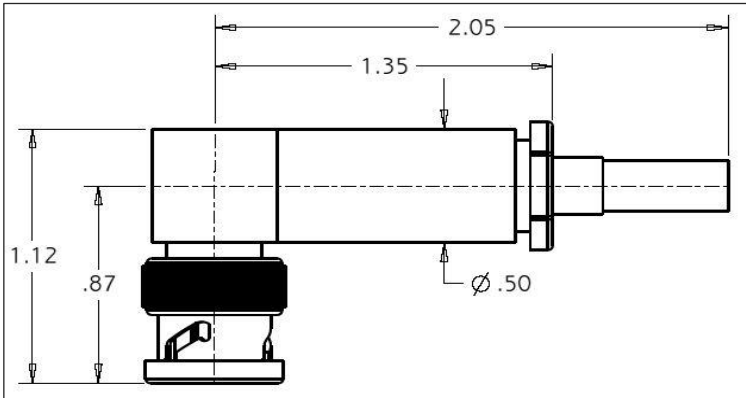
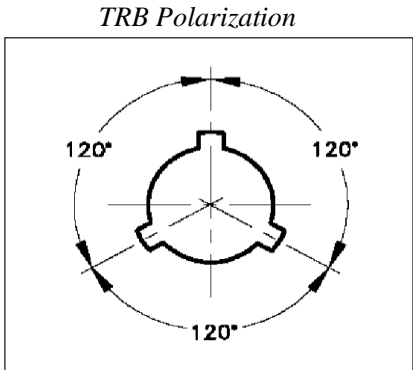

Features Not Shown: Seal in front

PERFORMANCE

Nominal Impedance	Non-Constant
Frequency Range	0 - 500 MHz
Voltage Rating	500 VRMS
Insulation Resistance	5000 Megohms

CONNECTOR WEIGHT

1.62 ounces (45.90 grams)

RoHS COMPLIANT

Complies to RoHS standards

INSTALLATION

Crimp Tooling:

<i>Crimp Ferrule</i>	M22520 / 5 - 01 Tool, Die Set M22520 / 5 - 43, Cavity B (.197" hex) (Daniels # Y141)
----------------------	---

CONSTRUCTION

Materials:

Body, Crimp Tube	Brass
Coupling Nut	Brass
Center Contact	Beryllium Copper
Dielectric	TFE Fluorocarbon

Finish :

Body, Crimp Tube	Nickel
Coupling Nut	Nickel
Center Contact	Gold

Applicable Standards MIL-C-49142

Notes :

- 1) A 2.5" piece of Raychem ATUM heat shrink P/N ATUM-16/4-0 provided with connector for purpose of strain relief & moisture protection.
- 2) Please refer to T-110466 Termination Instruction sheet for strip dimensions & instructions.