

PIC Wire & Cable <i>A Division of the Angelus Corporation</i> Ph 262-246-0500 Fax 262-246-0450 PO Box 330 Sussex, WI 53089	Connector Specification	120226
	Approved <i>MCT</i>	Date 06/23/10
	Distribution : USER	Rev. 2 (06/11/13) Uncontrolled Document

TNCA Panel Jack
for S28120 & HT77300F Cables

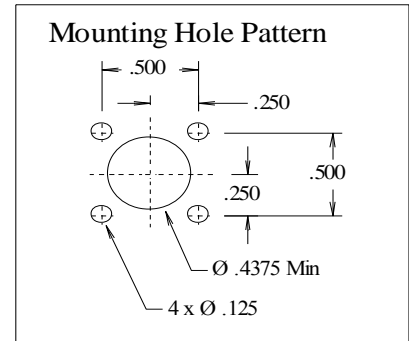
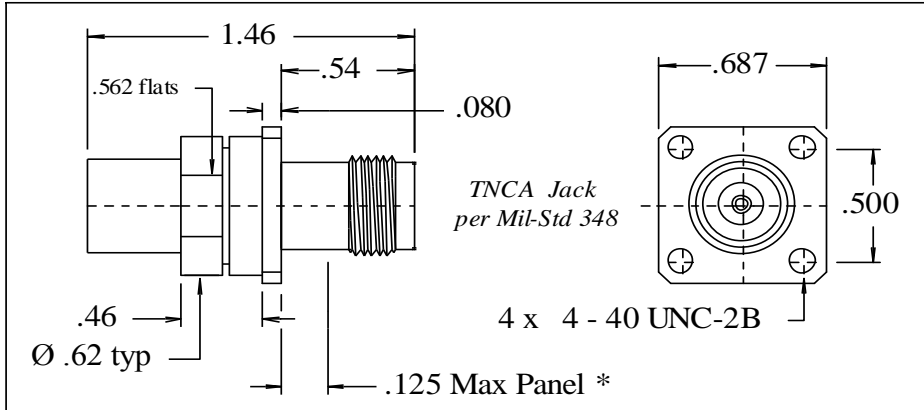

* For use Only on mounting panels using flush Flat Head Screws

PERFORMANCE

Nominal Impedance	50 Ohms
Frequency Range	DC - 18 GHz
Temperature Rating	- 65° to + 200° C
Voltage Rating	500 VRMS

CONNECTOR WEIGHT (Each)

.94 ounces (26.54 grams)

RoHS COMPLIANT

Complies to RoHS Standards

INSTALLATION

Solder-on Termination

CONSTRUCTION

Materials:

Body	Stainless Steel
Solder Bushing	Brass
Center Contact	Beryllium Copper
Dielectric	PTFE, Ultem

Finish :

Body	Passivated
Solder Bushing	Gold
Center Contact	Gold

<i>Applicable Standards</i>	MIL-STD 348B MIL-C-39012
-----------------------------	-----------------------------

Notes :

1) A 2.5" piece of Raychem ATUM heat shrink P/N ATUM-16/4-0 provided with connector for purpose of strain relief & moisture protection.

2) Please refer to T-120226 Termination Instruction sheet for strip dimensions & instructions.