

<b>PIC Wire &amp; Cable</b>	<b>Connector Specification</b>	<b>P/N 150114</b>
A Division of the Angelus Corporation Ph (262) 246-0500 Fax (262) 246-0450 www.picwire.com W220N1051 Springdale Rd, Waukesha, WI 53186	Approved : <i>FMB</i>	Date : 03/02/15
	Distribution : USER	Rev. 6 (12/21/22)
		Uncontrolled if Printed

**SMA 50 Ohm Straight Plug**  
for UH44193

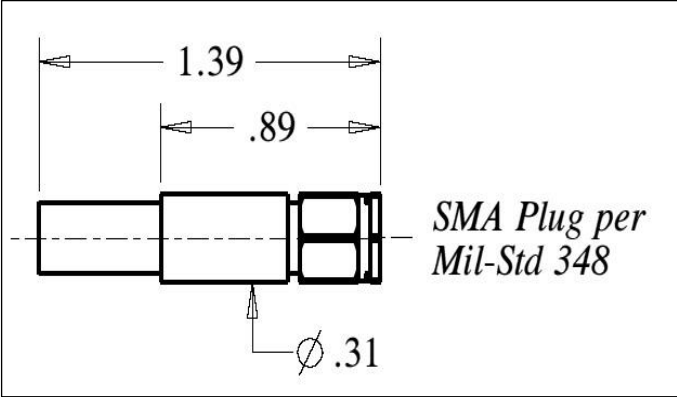

*Features Not Shown : Safety Wire Holes, Gasket in Front*

**PERFORMANCE**

Nominal Impedance :	50 Ohms
Frequency Range :	0 - 12 GHz
Voltage Rating :	335 V(rms)
Insulation Resistance :	5000 Megohms
DW Voltage :	750 V (rms)
Insertion Loss (max) :	0.20 dB max @ 12 GHz
Insertion Loss :	$0.06 \sqrt{F(\text{GHz})}$
Temperature Rating :	-65° to +165° C

**CONNECTOR WEIGHT (Each)**

0.34 ounces (9.53 grams)

**RoHS COMPLIANT**

Complies to RoHS Standards

**INSTALLATION**

**Center Contact**

M22520 / 1-01 Tool  
Selector Dial Setting #8  
Positioner : M22520 / 1-09

**Crimp Ferrule**

M22520 / 5-01 Tool  
M22520 / 5-11 Die Set  
(.213" A hex)

**CONSTRUCTION**

<b>Materials:</b>	
Body	Stainless Steel, ASTM-A582, Alloy UNS S30300
Cable Contact	Beryllium Copper, ASTM-B196, Alloy UNS C17300
Ferrule	Tellurium Copper PER ASTM B196 C14500, Temper-H02 Or Copper, ASTM-B152, Alloy C12200 Or Brass, ASTM-B16, Alloy UNS 36000, Dead Soft,
Dielectric	TFE Fluorocarbon, ASTM-D1710, Type 1, Grade 1
Gasket	Silicone Rubber

**Finish :**

Body	Passivated
Ferrule	Nickel
Center Contact	Gold

**APPLICABLE STANDARDS**

MIL-STD 348, MIL-PRF-39012

**Notes :**

- 1) A 1.5" piece of Raychem ATUM heat shrink P/N ATUM-12/3-0 provided with connector for purpose of strain relief & moisture protection.
- 2) Please refer to T-1501XX Termination Instruction sheet for strip dimensions & instructions.