

<b>PIC Wire &amp; Cable</b>	<b>Connector Specification</b>	<b>P/N 190209</b>
<i>A Division of the Angelus Corporation</i> Ph (262) 246-0500 Fax (262) 246-0450 www.picwire.com PO Box 330 Sussex, WI 53089	Approved : 	Date 12/21/92 Rev. 4 (06/16/14)
	Distribution : USER	Uncontrolled Document

**TNC 90° Plug**  
for PIC Cable T556124 or RG393

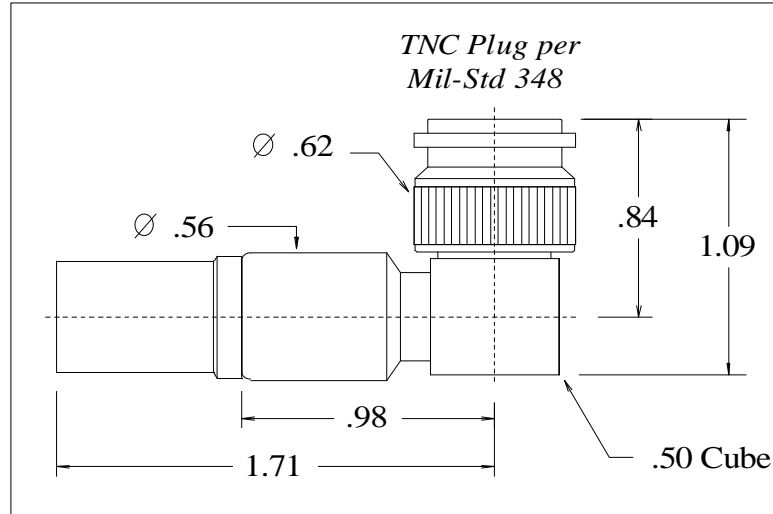

*Features Not Shown : Safety Wire Holes, Gasket in Front*

**PERFORMANCE**

Nominal Impedance	50 Ohms
Frequency Range	0 - 12 GHz
Voltage Rating	500 VRMS
Insulation Resistance	5000 Megohms

**CONNECTOR WEIGHT (Each)**

1.83 ounces (51.88 grams)

**RoHS COMPLIANT**

Complies to RoHS Standards

**INSTALLATION**

**Pic Die Set**

*Center Contact*  
M22520 / 5 - 01 Tool,  
PIC 190218 Hex Crimp Die  
(.098 hex)

*Crimp Ferrule*  
M22520 / 5 - 01 Tool,  
PIC 190218 Hex Crimp Die  
(.429/.450 hex)

**MIL Spec Die Set**

*Center Contact*  
M22520 / 5-01 Tool,  
MIL Spec \*M22520 / 5-25  
(.100 B hex)

*Crimp Ferrule*  
M22520 / 5-01 Tool,  
MIL Spec \*M22520 / 5-25  
(.429 A hex)

**CONSTRUCTION**

**Materials:**

Body	Brass, ASTM-B16, Alloy UNS 36000, H02
Center Contact	Beryllium Copper, ASTM-B196, Alloy UNS C17300
Ferrule	Brass, ASTM-B16, Alloy UNS 36000, Dead Soft, Weatherseals included
Dielectric	TFE Fluorocarbon, ASTM-D1710, Type 1, Grade 1

**Finish :**

Body, Ferrule	Nickel
Center Contact	Gold

**Applicable Standards**

MIL-STD 348  
MIL-PRF-39012

**Notes :**

- 1) A 2.5" piece of Raychem ATUM heat shrink P/N ATUM-19/6-0 provided with connector for purpose of strain relief & moisture protection.
- 2) Please refer to T-190XXX Termination Instruction sheet for strip dimensions & instructions.

\* Note - MIL Spec die to be used on the smaller diameter area of ferrule only. Not the larger "Bell" area on end.

*PIC Wire & Cable Connector User specification sheets are non-controlled documents. Please contact PIC Wire and Cable or visit the PIC website (www.picwire.com) to ensure the latest revision of the drawing is being viewed.*